

C80 mm

EXTERNAL VENETIAN COMPLETE WITH OPERATING MECHANISM EXCEPT VELETTES

The C80 external venetian is a model suitable for outdoor installation for large spans, with a 80mm curved slat bordered with an anti-noise gasket and rigid lateral sliding guides. It is ideal for mounting in opening or overhang. The slats can be adjusted in any position with a 180° movement with a dimming up to 75%. In the absence of the containment niche, it is possible to complete the installation with an external cover veil.

MINIMUM AND MAXIMUM DIMENSIONS C80 CRANK AND MOTOR

MAXIMUM DIMENSION IN WIDTH: 3800 mm
 MINIMUM DIMENSION IN WIDTH OF CRANK: 500 mm
 MINIMUM DIMENSION IN WIDTH WITH MOTOR: 550 mm
 MAXIMUM DIMENSION IN HEIGHT: 4500 mm
 MINIMUM DIMENSION IN HEIGHT: 500 mm
 MAXIMUM AREA: 8 sqm
 CRANK MINIMUM RECESS WIDTH: 130 mm

NOTES

For all external venetian models, the terylene is gray in colour.

FOR MEASURES OUTSIDE THE TABLE,
 CONTACT OUR TECHNICAL DEPARTMENT
 FOR PRODUCTION AND COSTS.

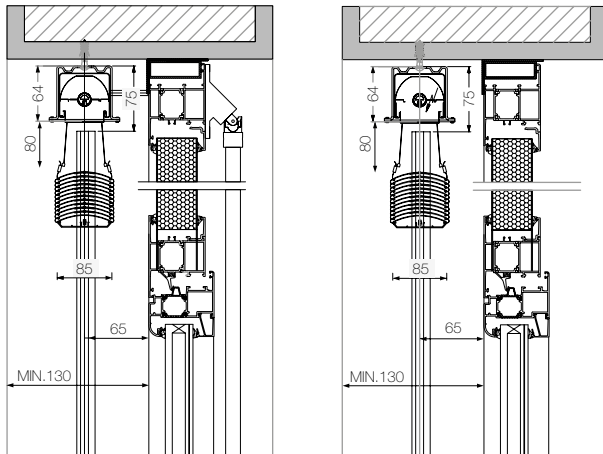

EXTERNAL VENETIAN C80 WITH CRANK

Aluminum crank \varnothing 15 mm with 90° transmission

MOTOR EXTERNAL VENETIAN C80

Power supply 230V / 50Hz

SIZE DETAILS

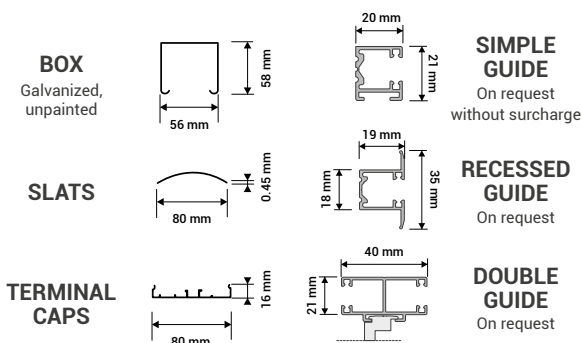

FINISHES AVAILABLE FOR GUIDES AND SLATS



NOTES: Painted box - price € 50,00 per LM

MANEUVER RODS (ALUMINUM CRANK \varnothing 15 mm)		
HEIGHT FR mm	SHAFT SUPPLIED mm	
1000	2500	1500
2600	3500	1800
3600	4500	2200

STAFFE CASSONETTO		
HEIGHT FR mm	N° SPACERS	
0	1700	2
1800	2600	3
2700	3500	4
3600	4000	5

BOX BRACKETS		
HEIGHT FR mm	N° BRACKETS	
0	1600	2
1601	2300	3
2301	3000	4
3001	3700	5
3701	4500	6